**Technical drawings — General principles of
presentation —**

Part 23:
Lines on construction drawings

Dessins techniques — Principes généraux de représentation —

*Partie 23: Traits utilisés dans la documentation de construction et de génie
civil*



Contents

1 Scope	1
2 Normative references	1
3 General principles	2
4 Types of lines and their applications	2
5 Line widths	4
Annex A (informative) Examples of application	6

© ISO 1999

All rights reserved. Unless otherwise specified, no part of this publication may be reproduced or utilized in any form or by any means, electronic or mechanical, including photocopying and microfilm, without permission in writing from the publisher.

International Organization for Standardization
Case postale 56 • CH-1211 Genève 20 • Switzerland
Internet iso@iso.ch

Printed in Switzerland

Foreword

ISO (the International Organization for Standardization) is a worldwide federation of national standards bodies (ISO member bodies). The work of preparing International Standards is normally carried out through ISO technical committees. Each member body interested in a subject for which a technical committee has been established has the right to be represented on that committee. International organizations, governmental and non-governmental, in liaison with ISO, also take part in the work. ISO collaborates closely with the International Electrotechnical Commission (IEC) on all matters of electrotechnical standardization.

International Standards are drafted in accordance with the rules given in ISO/IEC Directives, Part 3.

Draft International Standards adopted by the technical committees are circulated to the member bodies for voting. Publication as an International Standard requires approval by at least 75 % of the member bodies casting a vote.

International Standard ISO 128-23 was prepared by Technical Committee ISO/TC 10, *Technical drawings, product definition and related documentation*, Subcommittee SC 8, *Construction documentation*.

This first edition is based on ISO 128:1982, clause 3, and it replaces the rules specified in that clause.

ISO 128 consists of the following parts, under the general title *Technical drawings — General principles of presentation*:

- Part 20: Basic conventions for lines*
- Part 21: Preparation of lines by CAD systems*
- Part 22: Basic conventions and applications for leader lines and reference lines*
- Part 23: Lines on construction drawings*
- Part 24: Lines on mechanical engineering drawings*
- Part 25: Lines on shipbuilding drawings*
- Part 30: Basic convention for views*
- Part 50: Basic conventions for representing areas on cuts and sections*

NOTE Further parts of ISO 128 are planned, covering other general principles of presentation including those for application of lines within drawings of various technical fields.

Annex A of this part of ISO 128 is for information only.

Introduction

The basic conventions and the application of lines in respect to other fields of drawing practice are presented in other parts of ISO 128 since requirements in industry vary considerably. For further information, see ISO 128-20.

Technical drawings — General principles of presentation —

Part 23: Lines on construction drawings

1 Scope

This part of ISO 128 specifies types of lines and their application in construction documentation comprising architectural drawings, structural engineering drawings, building service engineering drawings, civil engineering drawings, landscape drawings and town planning drawings.

2 Normative references

The following normative documents contain provisions which, through reference in this text, constitute provisions of this part of ISO 128. For dated references, subsequent amendments to, or revisions of, any of these publications do not apply. However, parties to agreements based on this part of ISO 128 are encouraged to investigate the possibility of applying the most recent editions of the normative documents indicated below. For undated references, the latest edition of the normative document referred to applies. Members of ISO and IEC maintain registers of currently valid International Standards.

ISO 128-20:1996, *Technical drawings — General principles of presentation — Part 20: Basic conventions for lines.*

ISO 129:1985, *Technical drawings — Dimensioning — General principles, definitions, methods of execution and special indications.*

ISO 3766:1995, *Construction drawings — Simplified representation of concrete reinforcement.*

ISO 4068:1978, *Building and civil engineering drawings — Reference lines.*

ISO 4069:1977, *Building and civil engineering drawings — Representation of areas on sections and views* □
General principles.

ISO 4463-1:1989, *Measurement methods for building — Setting-out and measurement — Part 1: Planning and organization, measuring procedures, acceptance criteria.*

ISO 6428:1982, *Technical drawings — Requirements for microcopying.*

ISO 7519:1991, *Technical drawings — Construction drawings — General principles of presentation for general arrangement and assembly drawings.*

ISO 8048:1984, *Technical drawings — Construction drawings — Representation of views, sections and cuts.*

ISO 8560:1986, *Technical drawings — Construction drawings — Representation of modular sizes, lines and grids.*

ISO 11091:1994, *Construction drawings — Landscape drawing practice.*

3 General principles

The types of lines, their designations and their dimensions as well as general rules for draughting of lines are specified in ISO 128-20.

The requirements for microcopying are specified in ISO 6428.

4 Types of lines and their applications

The first part of the number is the number of line type in ISO 128-20.

Examples of applications are shown in annex A.

Table 1 — Types of lines and their application



No.	Description and representation	Application	Reference to ISO
01.1	Continuous narrow line 	.1 boundaries of different materials in view, cut and section (alternatively, see 01.2.2)	7519
		.2 hatching	4069
		.3 diagonals for indication of openings, holes and recesses	7519
		.4 arrow lines in stairs, ramps and sloping areas	7519
		.5 modular grid lines, first stage (if necessary, other colour than outlines)	8560
		.6 short centrelines	—
		.7 extension lines	129
		.8 dimension lines and their terminators	129
		.9 leader lines	129
		.10 existing contours on landscape drawings (alternatively, see 02.1.1)	11091
		.11 visible outlines of parts in view (alternatively, see 01.2.3)	—
		.12 simplified representation of doors, windows, stairs, fittings etc. (alternatively, see 01.2.4)	7519
		.13 framing of details	—
	Continuous narrow lines with zigzags 	.14 limits of partial or interrupted views, cuts and sections, if the limit is not a line 04.1 (alternatively, see 04.1.6)	—

Table 1 (continued)











No.	Description and representation	Application	Reference to ISO
01.2	Continuous wide line 	.1 visible outlines of parts in cut and section when hatching is used	7519
		.2 boundaries of different materials in view, cut and section (alternatively, see 01.1.1)	—
		.3 visible outlines of parts in view (alternatively, see 01.1.11)	7519
		.4 simplified representation of doors, windows, stairs, fittings etc. (alternatively, see 01.1.12)	7519
		.5 modular grid lines, second stage (if necessary other colour than outlines)	8560
		.6 arrow lines for marking of views, cuts and sections	8048
		.7 proposed contours on landscape drawings	11091
01.3	Continuous extra-wide line 	.1 visible outlines of parts in cut and section when hatching is not used	7519
		.2 reinforcing bars (see 02.3.1)	3766
		.3 lines of special importance	—
02.1	Dashed narrow line 	.1 existing contours on landscape drawings (alternatively, see 01.1.10)	11091
		.2 subdivision of plant beds/grass	11091
		.3 hidden outlines (alternatively, see 02.2.1)	—
02.2	Dashed wide line 	.1 hidden outlines (alternatively, see 02.1.3)	—
02.3	Dashed extra-wide line 	.1 reinforcing bars in bottom layer on plan and far face layer in elevation when bottom and top layers and near and far face layers are shown on the same sketch	3766
04.1	Long dashed dotted narrow line 	.1 cutting planes (line 04.2 at ends and changes of direction)	—
		.2 centrelines	—
		.3 lines of symmetry (identified at the ends by two narrow short parallel lines drawn at right angle)	—
		.4 framing of enlarged details	—
		.5 reference lines	—
		.6 limits of partial or interrupted views, cuts and sections (especially for short lines and in narrow situations; see examples 01.1.2, 01.2.1, 01.3.1, etc., in annex A; alternatively, see 01.1.14)	—

Table 1 (continued)

No.	Description and representation	Application	Reference to ISO
04.2	Long dashed dotted wide line 	.1 cutting planes (at ends and changes of direction; see 04.1.1)	—
		.2 outlines of visible parts situated in front of the cutting plane	—
04.3	Long dashed dotted extra-wide line 	.1 secondary lines for setting out and arbitrary reference lines	4463-1;4068
		.2 indication of lines or surfaces to which a special requirement applies	—
		.3 boundary lines for contracts, stages, zones etc.	—
05.1	Long dashed double-dotted narrow line 	.1 alternative and extreme positions of movable parts	—
		.2 centroidal line	—
		.3 outlines of adjacent parts	—
05.2	Long dashed double-dotted wide line 	.1 outlines of hidden parts situated in front of the cutting plane	—
05.3	Long dashed double-dotted extra-wide line 	.1 reinforcing prestressed bars and cables	3766
07.1	Dotted narrow line 	.1 outlines of parts not included in the project	—

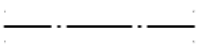
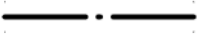
5 Line widths

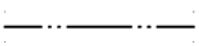
On a construction drawing three line widths, narrow, wide and extra-wide, are normally used (see Table 2).

The proportions between the line widths are 1:2:4.

A special line width is used for representation and lettering of graphical symbols. This line width is situated between the width of the narrow and the wide line.

Table 2 — Line widths

Dimensions in millimetres

Line group	Narrow line	Wide line	Extra-wide line	Line widths for graphical symbols
0,25	0,13	0,25	0,5	0,18
0,35	0,18	0,35	0,7	0,25
0,5	0,25	0,5	1	0,35
0,7	0,35	0,7	1,4	0,5
1	0,5	1	2	0,7

The line widths shall be chosen according to the type, size and scale of the drawing and the requirements at microcopying and other methods of reproduction.

Annex A (informative)

Examples of application

Examples of the application of the different types of lines, along with the corresponding reference numbers from clause 4, are given in Table A.1.

Table A.1 — Examples of application

No.	Line type	Example of application
01.1	Continuous narrow line	
01.1.1	Boundaries of different materials in view, cut and section	 <p style="text-align: right;">Line 01.1</p> <p style="text-align: center;">View of a floor with different materials</p>
01.1.2	Hatching	 <p style="text-align: right;">Line 01.1</p> <p style="text-align: right;">Line 04.1</p> <p style="text-align: center;">Vertical section of a wall</p>
01.1.3	Diagonals for indication of openings, holes and recesses	 <p style="text-align: right;">Line 01.1</p> <p style="text-align: center;">View of a wall with an opening</p>
01.1.4	Arrow lines in stairs, ramps and sloping areas	 <p style="text-align: center;">Stair Ramp</p>
01.1.5	Modular grid lines, first stage	 <p style="text-align: right;">Line 01.1</p>

Table A.1 (continued)



No.	Line type	Example of application
01.1.6	Short centrelines	
01.1.7 01.1.8 01.1.9	Extension lines Dimension lines and their terminators Leader lines	
01.1.10	Existing contours on landscape drawings	
01.1.11	Visible outlines of parts in view (alternatively, see 01.2.3)	
01.1.12	Simplified representation of doors, windows, stairs, fittings etc. (alternatively, see 01.2.4)	
01.1.13	Framing of details	
01.1.14	Limits of partial or interrupted views, cuts and sections, if the limit is not a line 04.1	

Table A.1 (continued)

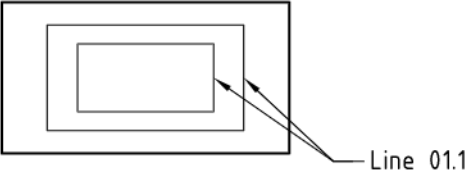
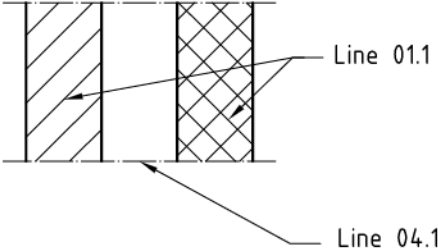
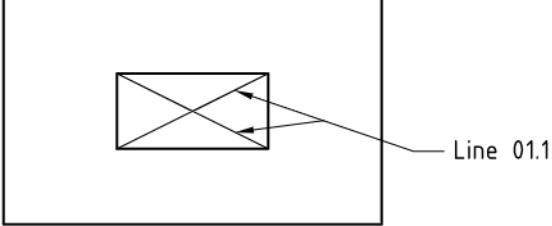
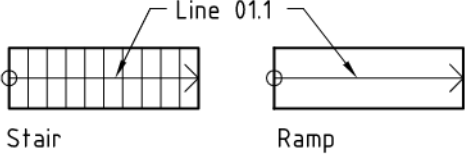
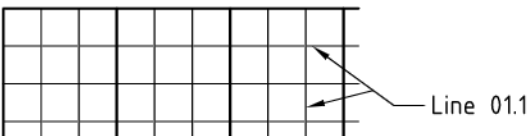

No.	Line type	Example of application
01.2	Continuous wide line	
01.2.1	Visible outlines of parts in cut and section when hatching is used	
01.2.2	Boundaries of different materials in view, cut and section	
01.2.3	Visible outlines of parts in view (alternatively, see 01.1.11)	
01.2.4	Simplified representation of doors, windows, stairs, fittings etc. (alternatively, see 01.1.12)	
01.2.5	Modular grid lines, second stage	
01.2.6	Arrow lines for marking of views, cuts and sections	
01.2.7	Proposed contours on landscape drawings	

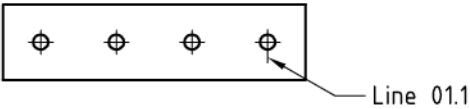
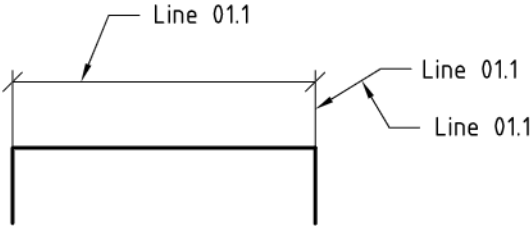
Table A.1 (continued)

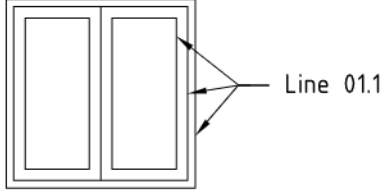
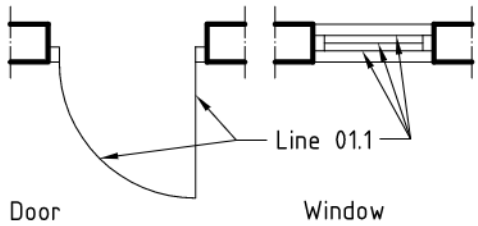
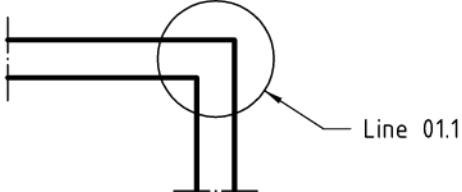
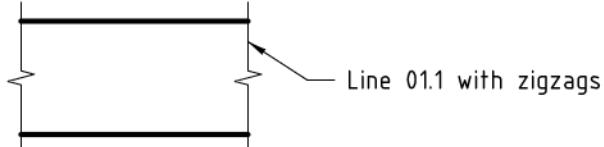

No.	Line type	Example of application
01.3	Continuous extra-wide line	
01.3.1	Visible outlines of parts in cut and section when hatching is not used	 <p style="text-align: center;">Vertical section of a wall</p>
01.3.2	Reinforcing bars	
02.1	Dashed narrow line	
02.1.1	Existing contours on landscape drawings (alternatively, see 01.1.10)	
02.1.2	Subdivision of plant beds/grass	
02.2	Dashed wide line	
02.2.1	Hidden outlines	
02.3	Dashed extra-wide line	
02.3.1	Reinforcing bars in bottom layer on plan and far face layer in elevation when bottom and top layers are shown on the same sketch	

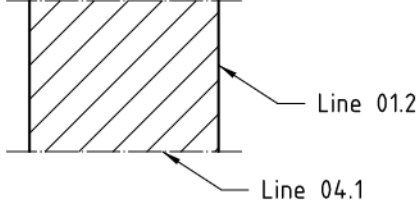
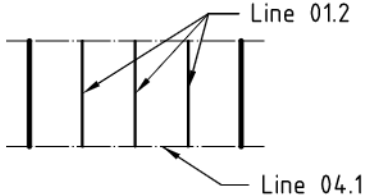
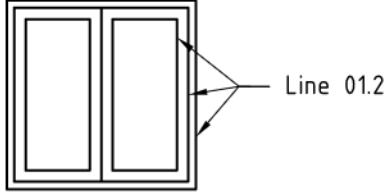
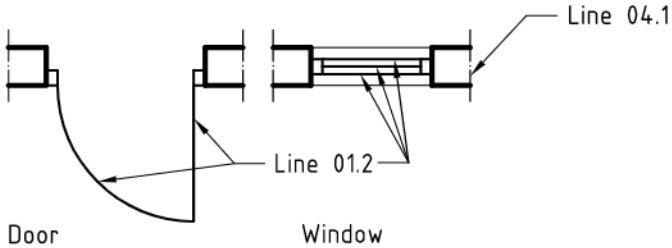
Table A.1 (continued)

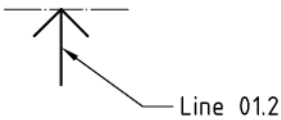
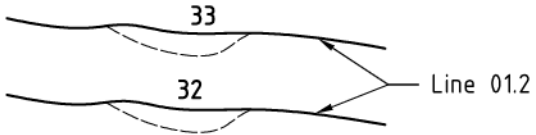
No.	Line type	Example of application
04.1	Long dashed dotted narrow line	
04.1.1	Cutting planes (drawn with line 04.2 at ends and changes of direction)	
04.1.2	Centrelines	
04.1.3	Lines of symmetry	
04.1.4	Framing of enlarged details	
04.1.5	Reference lines	
04.2	Long dashed dotted wide line	
04.2.1	Cutting planes (drawn with line 04.2 at ends and changes of direction; the rest is drawn with line 04.1)	

Table A.1 (continued)

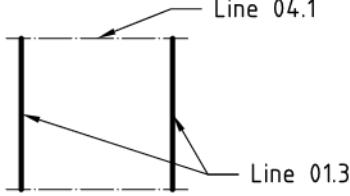
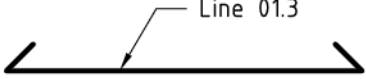
No.	Line type	Example of application
04.2.2	Outlines of visible parts situated in front of the cutting plane	
04.3	Long dashed dotted extra-wide line	
04.3.1	Secondary lines for setting out and arbitrary reference lines	
04.3.2	Indication of lines or surfaces to which a special requirement applies	
04.3.3	Boundary lines for contracts, stages, zones, etc.	
05.1	Long dashed double-dotted narrow line	
05.1.1	Alternative and extreme position of movable parts	
05.1.2	Centroidal lines	
05.1.3	Outlines of adjacent parts	

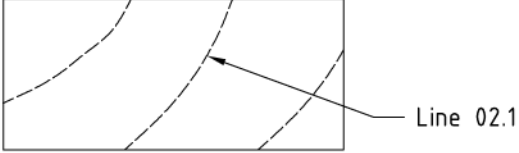
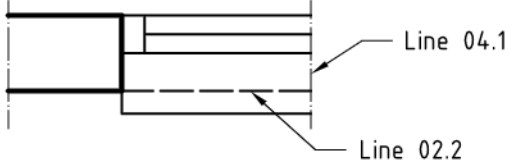
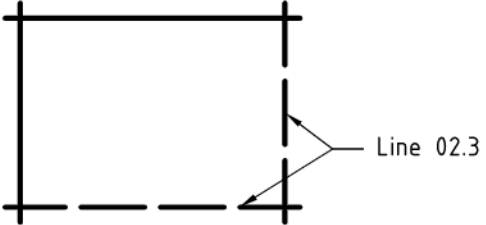
Table A.1 (continued)

No.	Line type	Example of application
05.2	Long dashed double-dotted wide line	
05.2.1	Outlines of hidden parts situated in front of the cutting plane	
05.3	Long dashed double-dotted extra-wide line	
05.3.1	Reinforcing prestressed bars and cables	
07	Dotted narrow line	
07.1	Outlines of parts not included in the project	

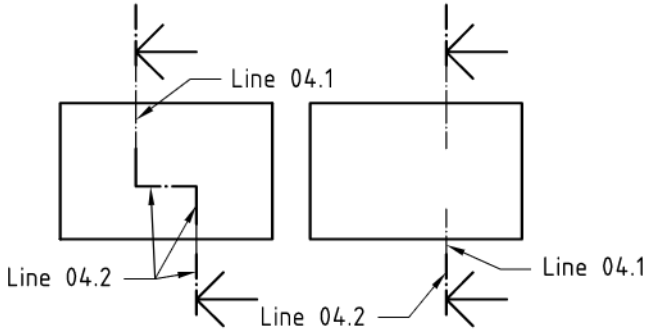
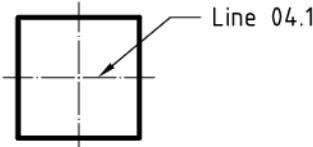
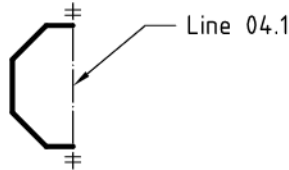
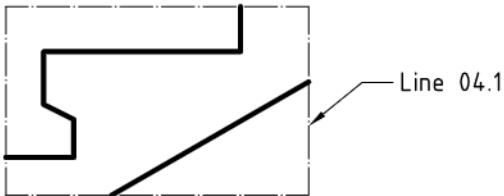
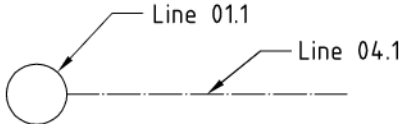
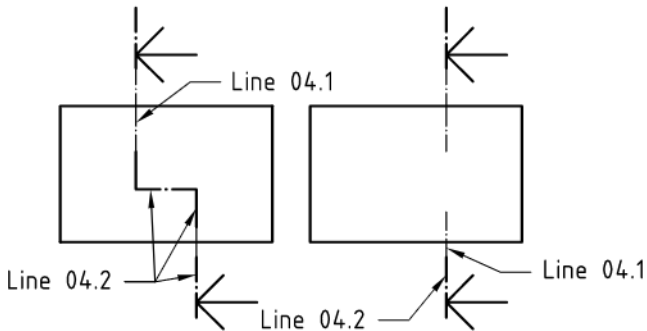
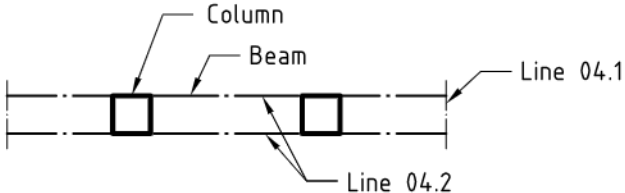
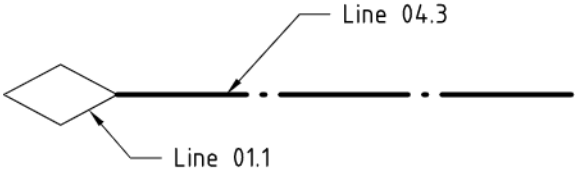
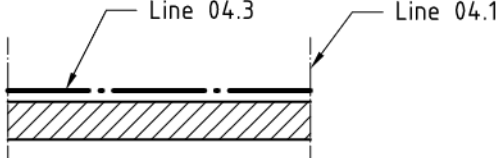
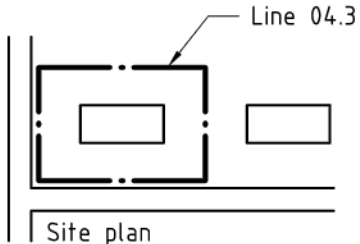
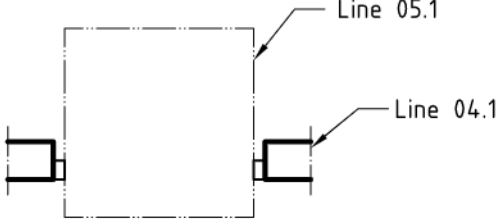
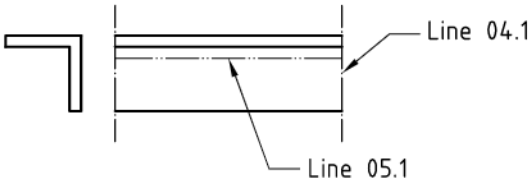
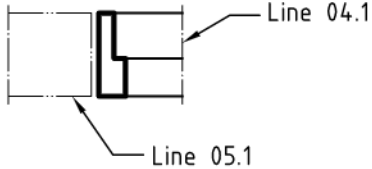
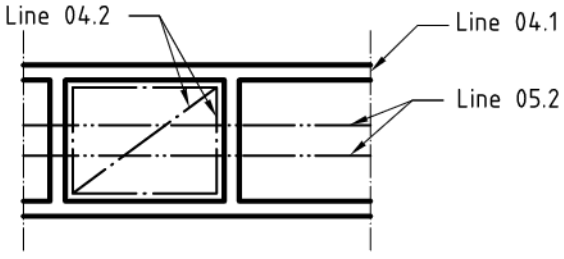
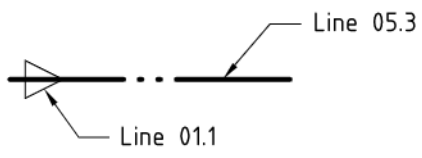
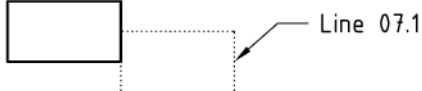
ICS 01.100.30

Price based on 12 pages
